

PUBLICATIONS INDEXED SINCE 1907 (*continued*).

Title of publication, etc.	How indexed.
<i>Scientific American</i> , "Cyc. of Receipts, etc.," (1892) (Chem. Syn.).....	page by page
<i>Society of Chemical Industry, Collective Index</i> (Vols. 1 to 14) ..	text cut and pasted
<i>Society of Chemical Industry, Vols. 15 to 19</i> (1896-1900).....	index cut and pasted
<i>Strecker, A.</i> , "Textbook of Organic Chemistry" (1882), pp. 789.....	index copied

## SOME NEW FORMS OF PROJECTION APPARATUS.

By L. M. DENNIS.

Received December 18, 1911.

The decomposition of water by electrolysis, the union of hydrogen and oxygen to form water, the electrolysis of hydrochloric acid, and other experiments with gases may satisfactorily be demonstrated before small classes by means of the lecture apparatus designed by Hofmann and others. When, however, the audience numbers several hundred, the apparatus is too small to render the details of the experiment clearly visible in all parts of the lecture room.

To obviate this difficulty, the small apparatus illustrated in Figs. 1 to 5 was designed for the projection of such experiments. Since round

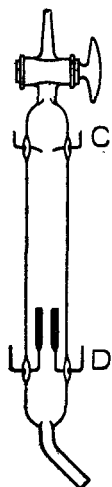

Fig. 1.

glass tubes are not suited to projection before the lantern, those parts of the apparatus that are to be projected upon the screen are made of flattened glass tubes with the sides as nearly parallel as possible. The main tubes of the apparatus shown in Figs. 1, 3 and 4 are 12 mm. wide and 4 mm. thick, while the tube C of Fig. 5 is 28 mm. wide and 14 mm. thick. As the usual diameter of the condensers of lanterns that are used for projection is about 11 cm., the height of that part of the apparatus that is to be projected upon the screen, for example, from the stopcock down to D in Fig. 1, is about 9 cm.

Fig. 1 shows an apparatus designed to illustrate the fact that the gases liberated when water is decomposed by an electric current recombine when the mixture is ignited by an electric spark and leave no gas residue. The tube is connected with the level tube (Fig. 2) by a piece of small rubber tubing about 25 cm. long, is filled with dilute sulfuric acid, and is held in front of the condenser of the lantern by a small clamp that grasps the tube just below the terminals D. The lower terminals are connected with a suitable source of direct current and the terminals at C are

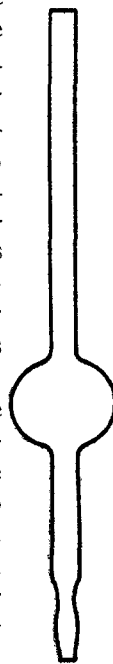

Fig. 2.

joined by light wires to the poles of a small induction coil. The current is then passed across the lower terminals, and when the evolved gas fills the tube down nearly to these terminals the current is shut off. Upon passing a spark between the upper terminals *C* the hydrogen and oxygen recombine and the confining liquid rises to the stopcock.

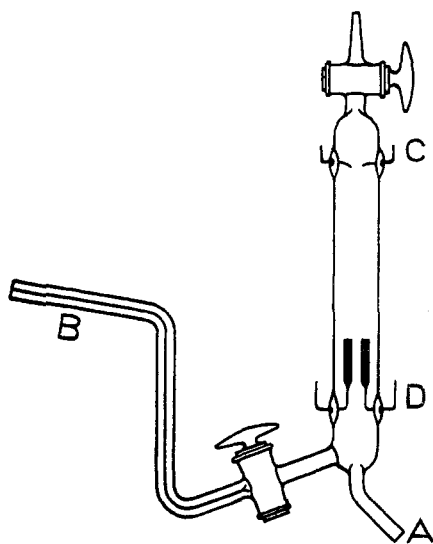

Fig. 3.

To show that a residue of gas remains after the explosion if either the hydrogen or oxygen be present in excess of the amount to which it is liberated when the water is decomposed by electrolysis, the tube shown in Fig. 3 is used. The end *A* is connected with the level tube as usual, and both the projection tube and the side capillary tube *B* are filled with dilute sulfuric acid. The end of the tube *B* is connected with an apparatus furnishing either hydrogen or oxygen. The current is then allowed to pass across the terminals at *D* until the tube is about half full of oxygen-hydrogen gas. The current is shut off, and hydrogen or oxygen is passed through *B* until the liquid falls to the terminals *D*. After explosion of the mixture, a volume of gas equal to that of the hydrogen or oxygen added will remain in the tube.

Fig. 4 shows an apparatus that may be used to demonstrate the relative volumes of hydrogen and oxygen that are set free when water is electrolyzed, or the relative volumes of hydrogen and chlorine that are set free when hydrochloric acid is electrolyzed. In the electrolysis of acidulated water, terminals of platinum wire are used; for the decomposition of hydrochloric acid, carbon terminals of the form shown in the illustration are employed. The level tube is here attached to the short side-arm *A*.

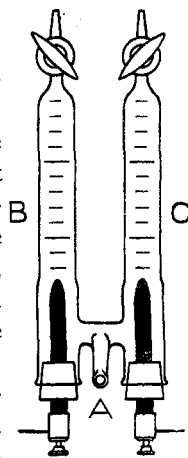

Fig. 4.

Fig. 5 is the decomposition tube of a Hempel nitrometer for showing the formation of nitric oxide when an aqueous solution of sodium nitrate is decomposed by concentrated sulfuric acid in the presence of mercury.

All of the above apparatus may be obtained from Greiner and Friedrichs, Stützerbach, Germany.

In the projection of chemical lecture experiments it is desirable to have the projection apparatus stand upon the lecture table where it may be manipulated by the lecturer himself. This usually necessitates the projection of the experiment upon a screen placed at the side of the lecture room where the images cannot easily be seen by students sitting close to the wall on that side of the room. By means of the arrangement shown in Fig. 6 the experiments that are to be projected may be performed upon the lecture table itself and the image reflected by the mirror *M* directly back upon the screen *S* behind the lecturer. The mirror *M* is simply a piece of heavy French mirror about 18 cm. square and mounted in a frame. To avoid distortion of the image upon the screen, the screen is mounted on a wooden frame that is hinged at the bottom and that can be set at any desired angle with the back wall by cords that are

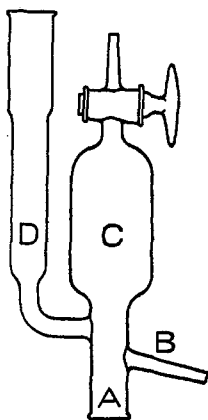

Fig. 5.

fastened to either edge and pass through pulleys on the wall down to the cleats *C*.

It is ordinarily impossible to show to more than a very few students at a time the interesting and instructive experiment of Mayer, described by J. J. Thompson<sup>1</sup> and others, in which small magnetized steel needles, thrust through disks of cork and floated upon water, assume in the magnetic field configurations that vary as the number of needles is changed. An attempt to project the experiment by throwing the light from the lantern up through a glass box containing water and the floating magnets and then reflecting the light upon the screen by a mirror, did not give satisfactory results because the bar magnet had to be placed below the lower

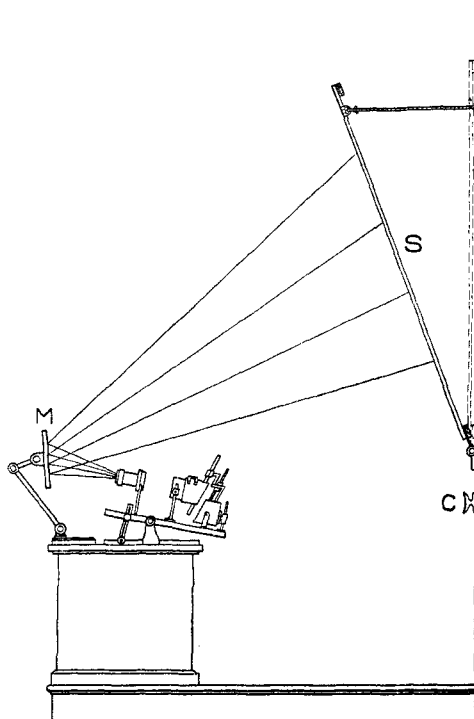

Fig. 6.

<sup>1</sup> "Electricity and Matter," Chapter 5, p. 114.

mirror or above the upper mirror at so considerable a distance from the needles that they did not readily assume the various groupings described by Mayer and did not readily change from one configuration to another. This difficulty has been cleverly overcome by Mr. F. H. Rhodes, of this laboratory, who uses in place of the bar magnet a solenoid fixed in position between the two mirrors as shown in Fig. 7. The light from the lantern is reflected upward by the mirror *M* through the solenoid *S*, the condenser *C*, and a Leybold glass cell *H*, and is then thrown upon the screen by the mirror *N* and the objective *O*. The solenoid consists of three layers of insulated No. 12 copper wire, 30 to 35 turns in each layer, wrapped around a porous cup from which the bottom has been cut off.

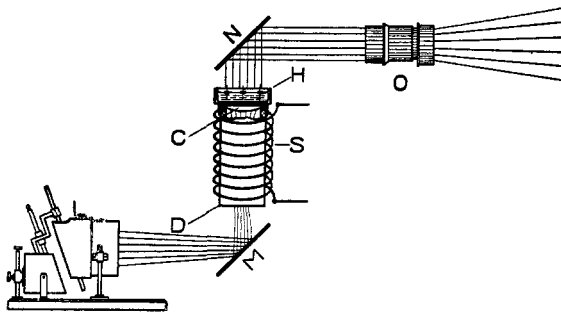

Fig. 7.

The dimensions of the cylinder *D* made from the porous cup are: inner diameter, 8 cm.; outer diameter, 9.5 cm.; and height, 22 cm. The solenoid may be held in place by fastening it in a ring attached to an iron retort stand. Resting upon the upper end of the porous cup is the condenser *C* which in this case was taken from another projecting lantern. The glass cell *H* measures 10 cm. on each side and is 3 cm. deep. It is filled nearly to the top with water and rests upon the face of the condenser *C*. *O* is the objective of the lantern itself.

The needles are ordinary, small, steel sewing needles about 27 mm. long. They were magnetized to as nearly equal strength as possible and were then thrust through thin cork disks about 7 mm. in diameter to such position that about two-thirds of the needle projected below the disk. The needles and corks were then dipped into molten paraffin. A current of from 7 to 8 amperes through the solenoid gives a field of such intensity that the needles when floated upon the water in *H* readily assume position and as readily show change in configuration when the number of needles is varied.